

# ILLUSTRATED PARTS LIST

MODEL NAMES	SERIAL NUMBER PREFIX	MODEL
Mac Cat -	11-	600160-02
Mac Cat-	11-	600160-03
Mac Cat -	11-	600160-04
Mac Cat -	11-	600160-05
Mac Cat -	11-	600160-06
Mac Cat -	11	600160-07
Mac Cat-	11-	600160-08

McCulloch products are identified by a model number (in this instance 000000) followed by a suffix number (02 or 03). Suffix numbers denote variations in parts or assemblies used in the manufacture of this product.

Illustrated Parts Lists (IPLs) contain a PART NUMBER, DESCRIPTION, UNITS per assembly and STOCKING CODE for each part. Stocking Codes are:

- A- Dealer stocked. Fast to medium moving part.
- B- Distributor stocked. Medium to slow moving part.
- C- Factory stocked. Slow moving part.
- T- Indicates a McCulloch service tool.
- N- No longer available.
- R- Replaced by.

NOTE: The following explains symbols/footnotes in this IPL

(-) A dash preceding a PART NUMBER indicates that it is a new part number, different from the one listed in the previous IPL for this unit.

(. .) One or more dots (. Spring-Starter) preceding a part DESCRIPTION indicates the part is included in the kit or assembly described directly above the dot(s).

(- - -) If four dashes appear in place of a PART NUMBER, the part is not available individually but is included in the next higher assembly or subassembly.

① ② Circled numbers preceding a DESCRIPTION footnote the part or assembly to additional information on the page.

(\* ) An asterisk draws attention to general information.

The policy of McCulloch Corporation is one of continual improvement in design, manufacturing and engineering advancement wherever possible to assure still finer power tools. Hence, specifications, equipment, colors, design and manufacturer's suggested list prices are subject to change without notice. McCulloch Corporation reserves the right to make such changes without prior notification or obligation to backfit or supply backfit components for units previously shipped from the factory.

JULY 1992

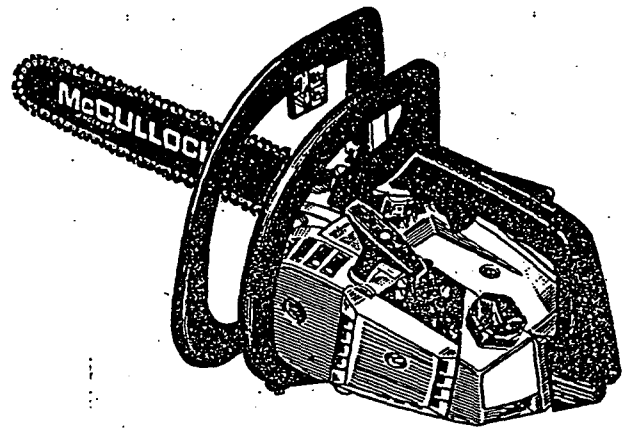
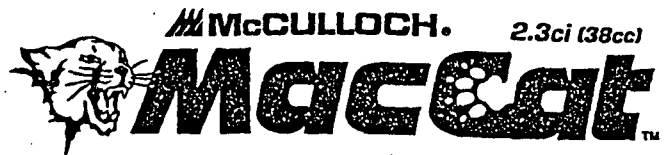

## CONTENTS

	PAGE
FIGURE 1 General Assembly . . . . .	2
FIGURE 2 Bar and Chain Information . . . . .	3
FIGURE 3 Powerhead Assembly . . . . .	4
FIGURE 4 Handle Assembly . . . . .	5
FIGURE 5 Chain Brake Assembly . . . . .	6
FIGURE 6 Carburetor Assembly . . . . .	7
FIGURE 7 Specifications . . . . .	8
FIGURE 8 Service Tools . . . . .	8



P.O. Box 11990 • Tucson, Arizona 85734

223344-01

© U.S.A. - McCulloch Corporation, 1992 • Printed in U.S.A.

# FIGURE 1

# GENERAL ASSEMBLY

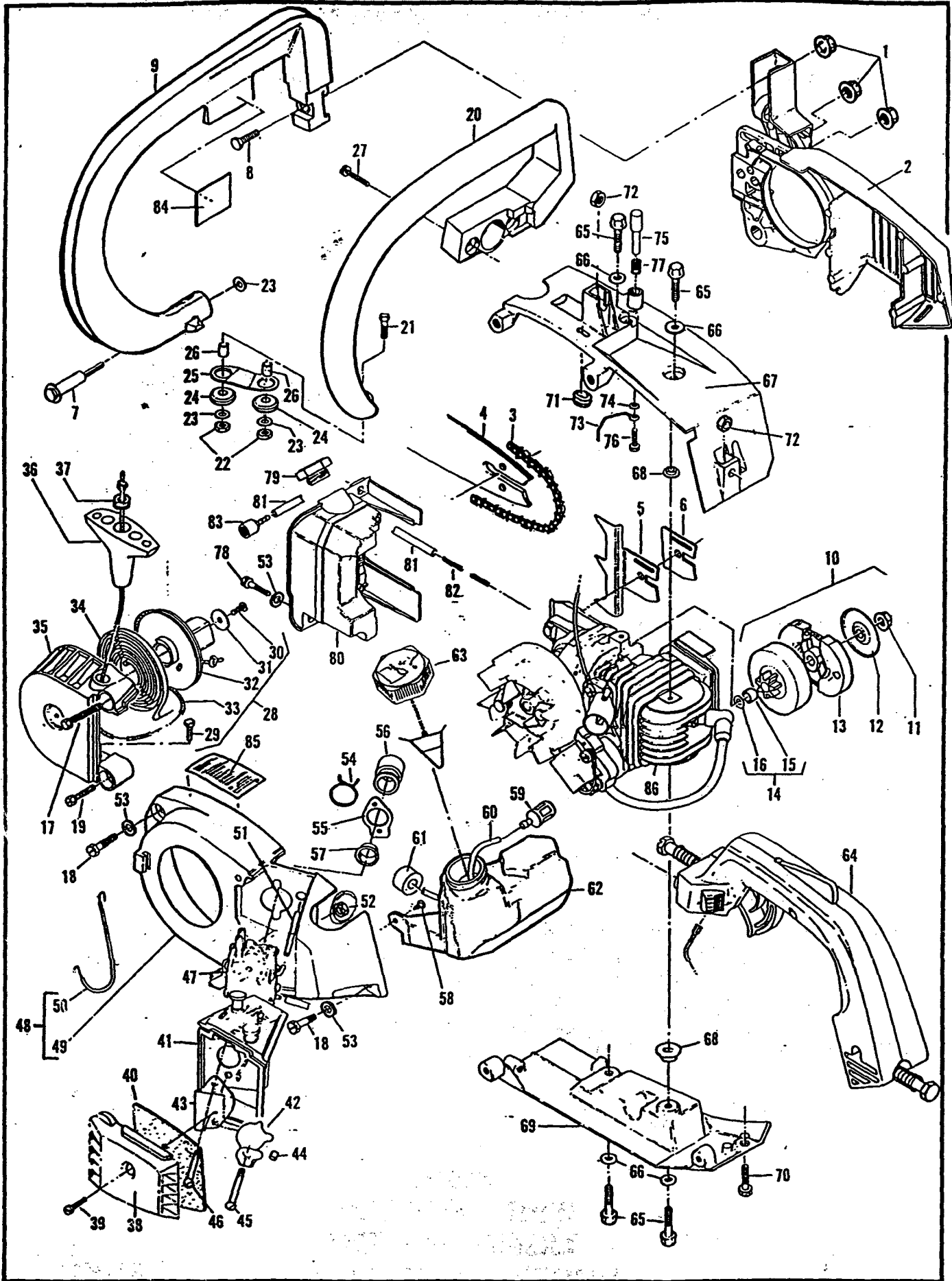

**FIGURE 1 GENERAL ASSEMBLY**

ITEM NO.	STK CODE	PART NUMBER	DESCRIPTION	UNITS PER ASY.	ITEM NO.	STK CODE	PART NUMBER	DESCRIPTION	UNITS PER ASY.
1	A	120029	Nut-M6.3x1.0 Fig.	3	44	B	213420	Spacer	1
2	-	Fig. 5	Chain Brake Assembly	1	45	B	213105	Screw-Pan M5x55	1
3	-	Fig. 2	Chain-18"	1	46	B	213104	Screw-Spec M5.8x50	1
4	-	Fig. 2	Bar-18"	1	47	-	Fig. 6	Carburetor Assembly	1
5	A	223087	Spike	1	48	B	-223962	Kit-Fan Housing	1
6	B	223074	Spacer-Bar Pad	1	49	C	-218556-01	. Housing-Fan	1
7	A	215695	Screw-Hx Spec M5	1	50	A	-213234-01	. Wire Assembly-Throttle	1
8	A	120028	Screw-Hx M6.3x1.0x20	1	51	A	-213542-01	Hose-Pulse	1
9	A	93021-01	Lever-Wraparound	1	52	A	217159	Nut-Hx M5	1
10	A	213278	Kit-Clutch Assembly	1	53	B	93469	Washer	4
11	B	94244	. Nut-Clutch	1	54	C	94302	Clip-Spring	1
12	B	94243	. Plate-Dust	1	55	B	92747	Flange-Carb. Mounting	1
13	-	--	. Clutch Assembly	1	56	A	92746	Boot-Carburetor	1
14	A	215252	Sprocket/Drum Asy	1	57	B	95656	Eyelet	1
15	A	-91117	. Bearing-Clutch	1	58	C	111002	Screw-Pan 10-16x.5	1
16	B	215259	. Washer-Sprocket	1	59	A	93720	Pickup-Fuel	1
17	B	120096	Screw-Hx M5x.8x55	1	60	A	-219971	Hose-Fuel	1
18	A	120095	Screw-Hx M5x.8x20	2	61	B	90869	Filter-Vent	1
19	A	120098	Screw-Hx M5x.8x18	1	62	A	216665	Tank Fuel	1
20	A	-216481	Frame	1	63	A	216157	Cap Asy-Fuel w/Retainer	1
21	B	216064	Bolt-M5 T-Head	1	64	-	Fig. 4	Handle Assembly	1
22	A	216585	Nut-Lock M5	2	65	A	213172	Screw-Hx M6x17	4
23	A	120045	Washer-M5	3	66	B	213021	Washer-Ramp Conical	4
24	A	110989	Grommet	2	67	B	223054	Shroud-Top	1
25	B	93152	Link	1	68	B	214350	Insulator-Baked	2
26	A	93057	Spacer-Mount	2	69	B	218555	Shroud-Bottom	1
27	B	218510	Screw-Pn M4x25 SEMS	2	70	A	120095	Screw-Hx M5x.8x20	1
28	B	-223836	Starter Assembly	1	71	B	94192	Grommet	1
29	B	216064	. Bolt-M5 T-Head	1	72	B	120034	Nut-Hx M6.3x1.0	2
30	B	110041	. Screw-Pn 8-32x.50	1	73	B	94540	Rod-Oiler	1
31	A	68497	. Washer	1	74	C	100001	Washer-Plain 6	1
32	A	-223835	. Drum/Rope Assembly	1	75	A	222509	Kit-Oil Knob	1
33	A	83203	. Rope-Starter	1	76	C	-110999	. Screw-Hx 6-20x16 WH S	1
34	A	83078	. Spring-Starter Rewind	1	77	B	93634-01	Spring-Compression	1
35	B	216485	. Housing Asy Starter	1	78	A	120095	Screw-Hx M5x.8x20	2
36	A	87851	Handle-Starter	1	79	A	216095	Cap-Asy Oil w/Retainer	1
37	B	-223944	Bushing-Starter	1	80	B	223052	Tank Assembly-Oil	1
38	B	215481	Cover Asy-Air Filter	1	81	A	94405	. Hose-Pickup	1
39	A	213118	. Screw-Air Filter Cover	1	82	A	93998	. Spring-Oil Hose	1
40	A	322001	Filter-Air	1	83	B	-225062	. Pickup-Oil	1
41	B	215482	Airbox Assembly	1	84	B	219058	Decal-Safety	1
42	B	213411	Plate-Choke	1	85	C	218558	Plate-Instruction	1
43	B	215455	Bracket-Choke	1	86	-	Fig. 3	Powerhead Assembly	1

**BAR and CHAIN INFORMATION**

**FIGURE 2**

PART NUMBER	STK. CODE	BAR DESCRIPTION	PART NUMBER	STK. CODE	CHAIN DESCRIPTION	FILE PLATE PART #	STK. CODE	ROUND FILE PART #	STK. CODE
214236-01	B	16" Spkt Tip	218097-12	C	MP 370 GLX 55 CL	219131	C	214217	C
219276-01	B	18 " Spkt. Tip	219275-12	C	MP 370 GLX 60 CL				

# FIGURE 3 POWERHEAD ASSEMBLY

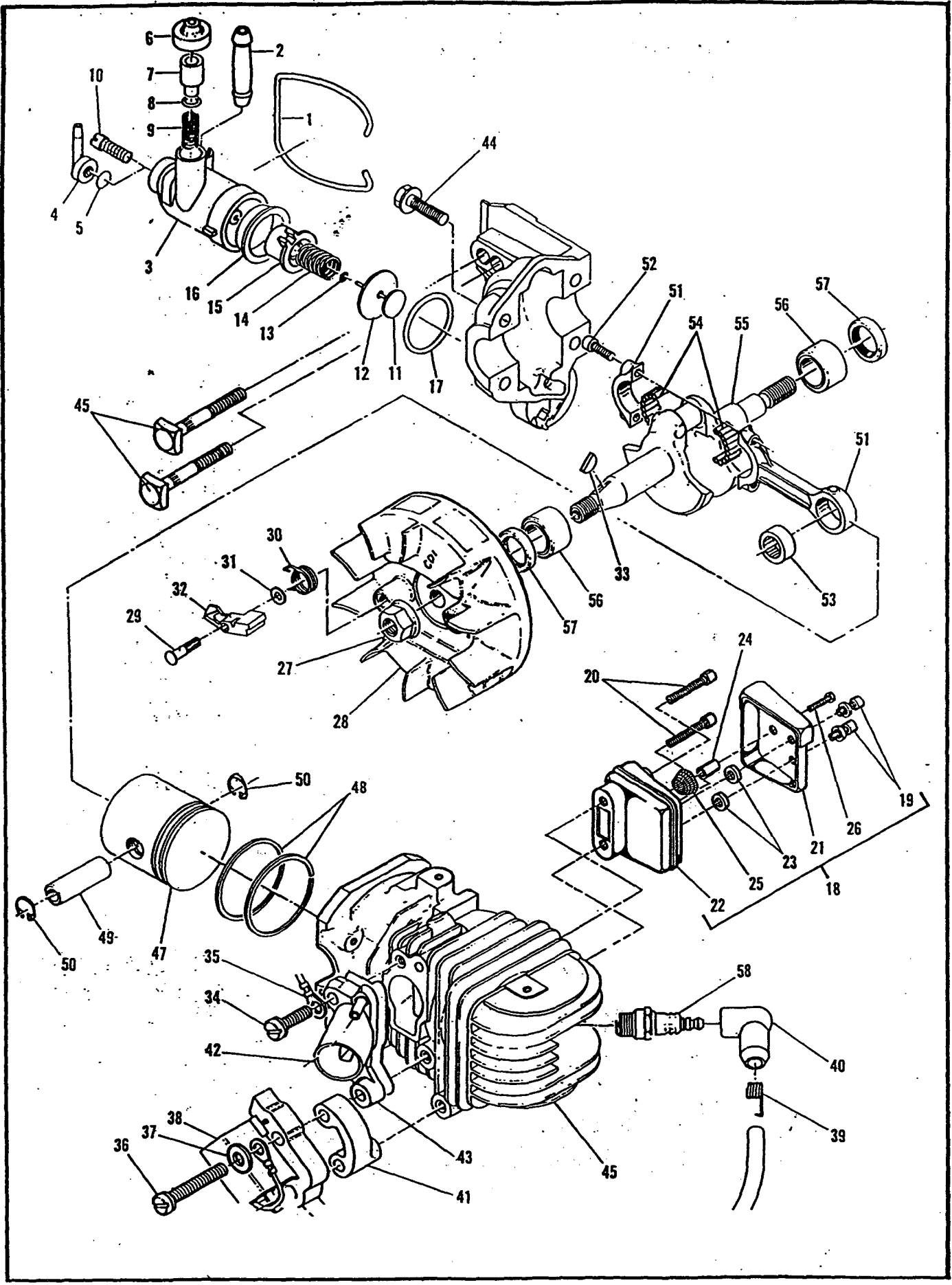

### FIGURE 3 POWERHEAD ASSEMBLY

ITEM NO.	STK CODE	PART NUMBER	DESCRIPTION	UNITS PER ASY.
1	C	93150	Bail	1
2	A	217168	Connector-Oil Pump Outlet	1
3	A	-219990-01 ④	Pump Assembly-Oiler	1
4	C	215196	Connector Hose	1
5	A	94115	Valve-Oiler	1
6	A	215151	Cap-Oil Pump	1
7	B	93301	Plunger-Oil Pump	1
8	A	105614	"O" Ring .239x.070	1
9	C	93632	Spring	1
10	B	-217765	Screw-Adjustment	1
11	B	-223651	Piston Assembly-Oiler	1
12	-	--	Ring-Oil Pump	1
13	A	105603	"O" Ring-.114x.070	1
14	B	83891	Spring-Return	1
15	B	216423	Sleeve-Oil Pump	1
16	C	216422	Eyelet	1
17	A	110653	"O" Ring	1
18	B	-223610	Kit-Muffler	1
19	C	-223635	Screw-Skt Hd 10-24x.5	2
20	A	215394	Screw-Special Muffler	2
21	C	-223611	Cover/Deflector Asy	1
22	C	-215410	Body/Cover Asy	1
23	C	-223637	Spacer-.21 ID x.44 OD x.12	2
24	C	-223827	Spacer-Muffler	1
25	C	-83407	Screen-Spark Arrestor	1
26	C	-223828	Screw-Pn Hd 6-32x.750	1
27	A	-213169	Nut-Hx Flange M8	1
28	B	219211 ① ③	Flywheel/Pawl Assembly	1
	B	-222778 ② ③	Flywheel/Pawl Assembly	1
29	B	216984	Pin-Starter Pawl	2

ITEM NO.	STK CODE	PART NUMBER	DESCRIPTION	UNITS PER ASY.
30	B	216982	Spring-Starter Pawl	2
31	B	93469	Washer-Starter Pawl	2
32	A	216983	Pawl-Starter	2
33	A	102164	Key-Flywheel	1
34	A	120098	Screw-Hx M5x.8x18	1
35	B	93514-01	Wire Assembly-Ground	1
36	C	120112	Screw-Skt M5x.8x.40	1
37	A	216591	Washer-Flat M5	2
38	A	219215 ① ③	Ignition Assembly	1
	B	-223707 ② ③	Kit Ignition	1
39	A	102556	Connector-Spark	1
40	A	95266	Boot-Spark Plug	1
41	B	214356	Spacer-Baked	1
42	B	215601	Manifold-Carburetor	1
43	A	92778	Gasket-Manifold	1
44	B	120097	Screw-Hx M5x.8x25	4
45	B	-223719	Cylinder/C'Case Assembly	1
46	A	92777	Bolt-Bar	2
47	B	223048	Piston-Mach	1
48	B	91703	Set-Piston Rings (2)	1
49	C	92836	Pin-Piston	1
50	C	111026	Ring-Snap	2
51	B	94135	Connecting Rod/Bearing Asy	1
52	B	94654	Screw-Connecting Rod	2
53	A	110984	Bearing-Needle	1
54	B	68095	Set-Needle Roller (20)	1
55	B	92750	Crankshaft	1
56	A	213282	Bearing-Crankshaft	2
57	A	83859	Seal-Crankshaft	2
58	A	63432	Spark-Plug	1

- ① These parts must be used as a set. The Flywheel can be identified by the letters "CDI" stamped on it. The Ignition can be identified by its black color and the code (AM32) stamped on the Ignition Module.
- ② These parts must be used as a set and cannot interchange with the parts identified with footnote (1). The Flywheel is identified by the letter "F" stamped on it. The Ignition is cream in color.

- ③ When replacing both Flywheel and Ignition order P/N 223706 Flywheel Ignition Kit.
- ④ When repair of the Oil Pump is necessary order P/N 216426-01 this kit includes Items 11 thru 16.

### HANDLE ASSEMBLY FIGURE 4

ITEM NO.	STK CODE	PART NUMBER	DESCRIPTION	UNITS PER ASY.
1	A	93529	Bolt-Shoulder	2
2	A	93530-01	Spring-Mount	4
3	A	92704	Mount	1
4	A	94038	Hub-Mount	1
5	A	213230	Handle Assembly	1
6	A	111032	Screw-Pan 10-16x.625	4
7	A	92704	Mount	1
8	A	94038	Hub-Mount	1
9	A	213229	Handle-Right Half	1
10	A	213228	Handle-Left Half	1
11	A	93310	Trigger-Safety	1
12	A	93515	Spring-Trigger	1
13	A	213232	Trigger-Throttle	1
14	A	-213234-01	Wire Asy-Throttle	1
15	A	110706	Screw-Pn 8-18x.50 St H	1
16	B	62451	Contact-Ignition Switch	1
17	B	93505-01	Wire-Stop Switch	2
18	A	68846	Button-Stop Switch	1

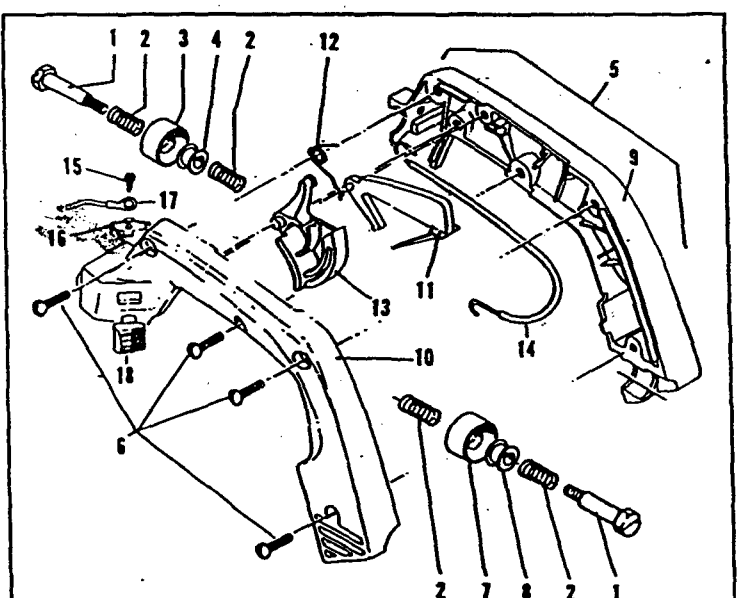

CM 21323001 COMPLETE TOP HANDLE

# FIGURE 5

# CHAIN BRAKE ASSEMBLY

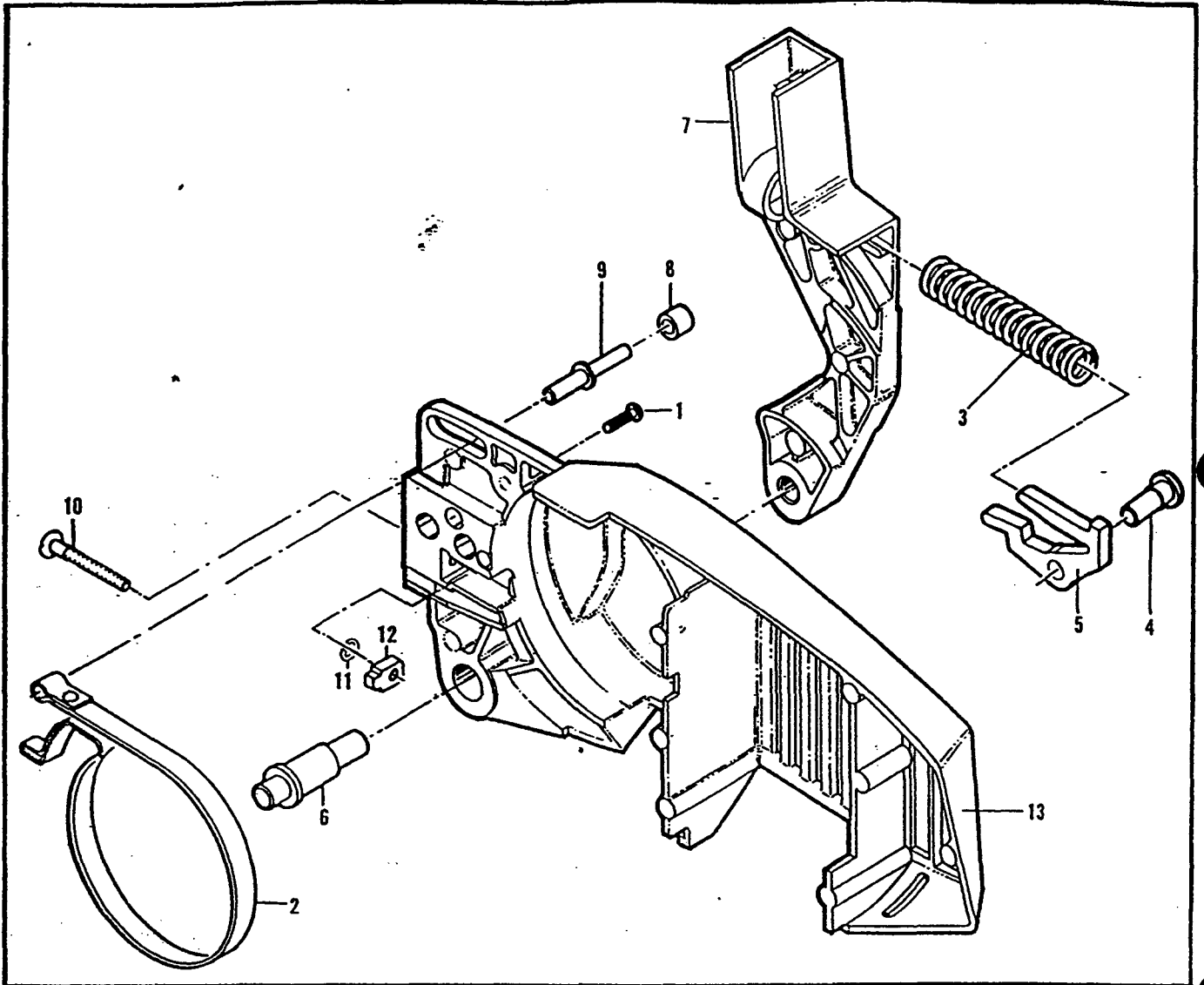

ITEM NO.	STK. CODE	PART NUMBER	DESCRIPTION	UNITS PER ASY.
	B	-223615	Brake Assembly-Chain	1
1	B	111047	. Screw-Fil 8-32x.625 TT	1
2	A	94709	. Band-Brake	1
3	B	215721	. Spring-Compression	1
4	B	93602	. Pivot Latch	1
5	C	216755	. Latch-Chain Brake	1
6	C	216549	. Pivot-Lever	1

ITEM NO.	STK. CODE	PART NUMBER	DESCRIPTION	UNITS PER ASY.
7	A	216268	. Lever-Actuating	1
8	A	214368	. Bearing-Roller	1
9	B	213907	. Pin-Roller	1
10	A	223088	. Screw-Adjusting	1
11	A	110907	. Ring Retaining	1
12	A	68656	. Nut-Bar Adjusting	1
13		---	. Housing-Brake	1

# CARBURETOR ASSEMBLY

# FIGURE 6

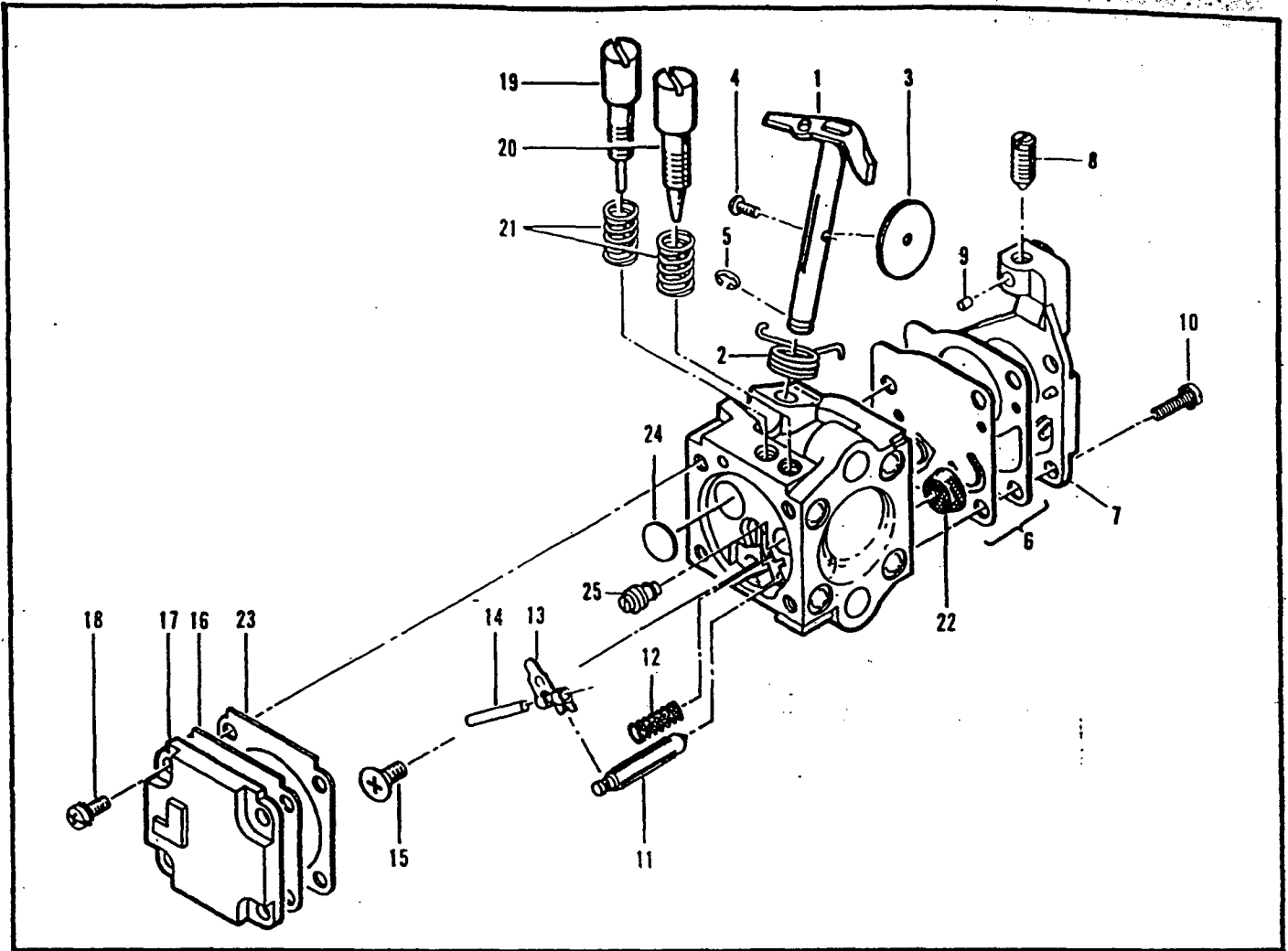

ITEM NO.	STK CODE	PART NUMBER	DESCRIPTION	UNITS PER ASY.
	A	94496	Carburetor	1
1	-	---	. Shaft Asy-Throttle	1
2	-	---	. Spring-Throttle Return	1
3	-	---	. Plate-Throttle	1
4	-	---	. Screw-Plate	1
5	-	---	. Ring-"E"	1
6	-	---	① ② . Kit-Diaphragm/Gasket	1
7	C	94206	. Cover Asy-Pump	1
8	-	---	. Screw-Idle Speed	1
9	-	---	. Insert-Friction	1
10	-	---	. Screw-Pump Cover	4
11	-	---	① . Needle-Inlet	1
12	-	---	① . Spring-Lever	1

ITEM NO.	STK CODE	PART NUMBER	DESCRIPTION	UNITS PER ASY.
13	-	---	① . Lever-Inlet Needle	1
14	-	---	① . Pin-Lever	1
15	-	---	① . Screw-Lever Pin	1
16	-	---	① ② . Diaphragm Asy-Metering	1
17	-	---	. Cover-Diaphragm	1
18	-	---	. Screw Diaphragm Cover	4
19	-	---	. Screw-Idle Adjust	1
20	-	---	. Screw-Main Adjust	1
21	-	---	. Spring-Needle	2
22	-	---	① . Screen-Filter	1
23	-	---	① . Gasket-Metering Diaph.	1
24	-	---	① . Plug-Welch	1
25	-	---	① . Orifice-Main Fuel	1

NOTE: Carburetor parts are shown for identification and disassembly sequence purposes only. Components are not available separately unless a part number is listed before the part description.

① Contained in Major Repair Kit, P/N 300460 (CODE C).  
 ② Contained in Gasket/Diaphragm Kit, P/N 300467 (CODE A).

**FIGURE 7****SPECIFICATIONS**

BAR LENGTH	16 to 18 Inches
DRY WEIGHT	12 Lbs
CYLINDER	Aluminum with Chrome Bore
DISPLACEMENT	2.3 cu. In. (38cc)
BORE AND STROKE	1.56 in. (39.7mm)x 1.2 in. (30.5mm)
IDLE SPEED	2700 to 2900 R.P.M.
CLUTCH ENGAGEMENT SPEED	3800 R.P.M.
IGNITION	Electronic
FLYWHEEL TO LAMINATION GAP	.011 (0.3mm) to .015 in.(0.4mm)
FUEL TANK CAPACITY	11.2 Fl. ounces
OIL TANK CAPACITY	3.4 Fl. ounces

**FIGURE 8****TOOLS/ACCESSORIES**

PART NUMBER	STK. CODE	DESCRIPTION
94364-01	A	Carrying Case 18"
93797	T	Wrench-Screwdriver
91226	T	Wrench-Flywheel Clutch
85229	T	Kit-Pressure Test MM6
215432	T	Tool Pressure Test

**TO ANSWER SERVICE-RELATED  
QUESTIONS AND TO SOLVE COMMON  
CONSUMER PROBLEMS QUICKLY,  
CALL THIS TOLL-FREE HOT-LINE:**

**1-800-423-6302**

IF LOCATED IN ARIZONA, CALL:

**1-800-221-6507**